

# NET24N

**DEA**<sup>®</sup>

move as you like

- IT** **Quadro di comando programmabile**  
*Istruzioni d'uso ed avvertenze*
- EN** **Programmable control board**  
*Operating instructions and warnings*
- FR** **Armoire de commande programmable**  
*Notice d'emploi et avertissements*
- DE** **Programmierbare Steuereinheit**  
*Bedienungsanleitung und Hinweise*
- ES** **Cuadro de maniobra programable**  
*Instrucciones de uso y advertencias*
- PT** **Quadro de comando programável**  
*Instruções para utilização e advertências*
- PL** **Uniwersalna centrala sterująca**  
*Instrukcja montażu i użytkowania*
- RU** **Программируемая панель управления**  
*Инструкции и предупреждения*

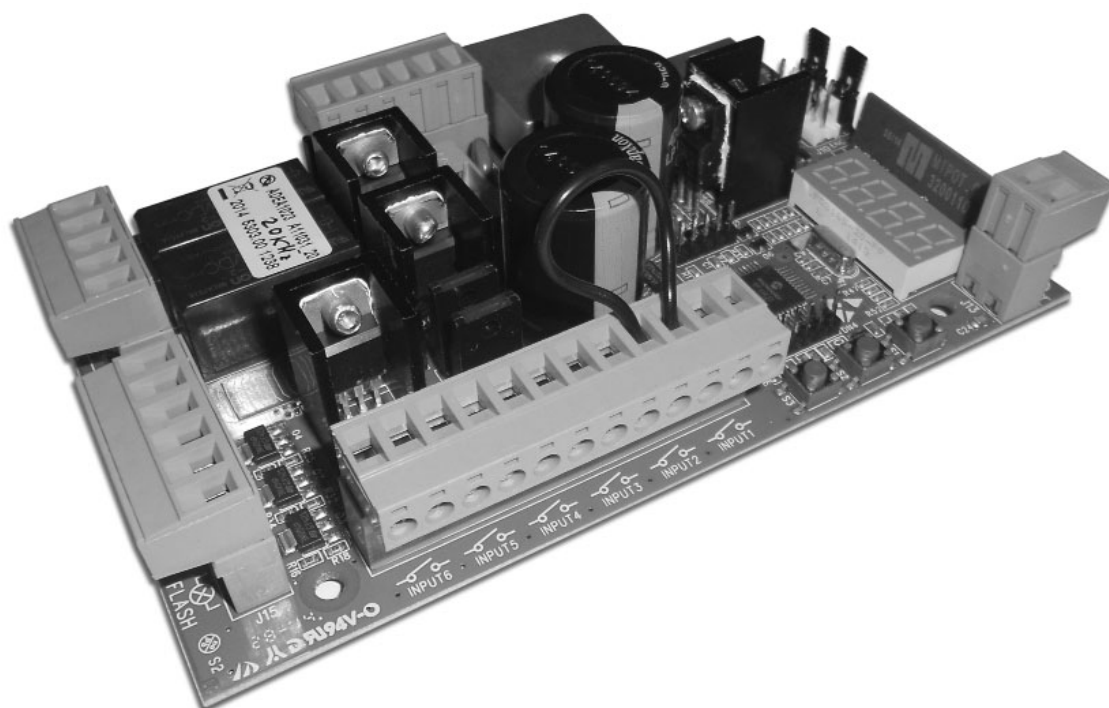

# NET24N

**Universal control panel for 24V operators**  
Operating instructions and warnings

## Index

<b>1</b>	Warnings Summary	<b>EN-1</b>	<b>6</b>	Standard Programming	<b>EN-11</b>
<b>2</b>	Product Description	<b>EN-3</b>	<b>7</b>	Advanced Programming	<b>EN-15</b>
<b>3</b>	Technical data	<b>EN-3</b>	<b>8</b>	Messages shown on the Display	<b>EN-18</b>
<b>4</b>	Configurations	<b>EN-4</b>	<b>9</b>	Installation Test	<b>EN-19</b>
<b>5</b>	Electrical Connections	<b>EN-5</b>	<b>10</b>	Product Disposal	<b>EN-19</b>

## 1 WARNINGS SUMMARY

**WARNING! IMPORTANT SAFETY INSTRUCTIONS. CAREFULLY READ AND FOLLOW ALL WARNINGS AND INSTRUCTIONS THAT ACCOMPANY THE PRODUCT SINCE INCORRECT INSTALLATION COULD CAUSE HARM TO PEOPLE, ANIMALS OR THINGS. WARNINGS AND INSTRUCTIONS PROVIDE IMPORTANT INFORMATION REGARDING SAFETY, INSTALLATION, USE AND MAINTENANCE. KEEP THE INSTRUCTIONS TOGETHER THE TECHNICAL DOCUMENTATION AND FOR FUTURE REFERENCE.**

⚠ **WARNING** The device may be used by children of less than 8 years of age, people with reduced physical, mental or sensory impairment, or generally anyone without experience or, in any case, the required experience provided the device is used under surveillance or that users have received proper training on safe use of the device and are aware of the dangers related to its use.

⚠ **WARNING** Do not allow children to play with the device, the fixed commands or the radio controls of the system.

⚠ **WARNING** Product use in abnormal conditions not foreseen by the manufacturer may generate hazardous situations; meet the conditions indicated in these instructions.

⚠ **WARNING DEA** System reminds all users that the selection, positioning and installation of all materials and devices which make up the complete automation system, must comply with the European Directives 2006/42/CE (Machinery Directive), 2014/53/UE (RED Directive). In order to ensure a suitable level of safety, besides complying with local regulations, it is advisable to comply also with the above mentioned Directives in all extra European countries.

⚠ **WARNING** Under no circumstances use the device in an explosive atmosphere or in areas that may be corrosive or could damage product parts. Check that the temperatures at the installation site are suitable and comply with the temperatures declared on the product label.

⚠ **WARNING** When working with the “dead man” switch, make sure that there are no people in the area where the automatism is being used.

⚠ **WARNING** Check that there is a switch or an omni polar magneto-thermal circuit breaker that enables complete disconnection in case of over voltage category III conditions installed upstream from the power system.

⚠ **WARNING** To ensure an appropriate level of electrical safety always keep the 230V power supply cables apart (minimum 4mm in the open or 1 mm through insulation) from low voltage cables (motors power supply, controls, electric locks, aerial and auxiliary circuits power supply), and fasten the latter with appropriate clamps near the terminal boards.

⚠ **WARNING** If the power cable is damaged, it must be replaced by the manufacturer or its technical assistance service or, in any case, by a person with similar qualifications to prevent any risk.

⚠ **WARNING** All installation, maintenance, cleaning or repair operations on any part of the system must be performed exclusively by qualified personnel with the power supply disconnected working in strict compliance with the electrical standards and regulations in force in the nation of installation.

Cleaning and maintenance destined to be performed by the user must not be performed by unsupervised children.

⚠ **WARNING** Using spare parts not indicated by **DEA** System and/or incorrect re-assembly can create risk to people, animals and property and also damage the product. For this reason, always use only the parts indicated by **DEA** System and scrupulously follow all assembly instructions.

⚠ **WARNING** Changing the closing intensity could lead to dangerous situations. Therefore, qualified personnel should only perform increases to the closing force. After adjustment, compliance with regulatory limits values should be detected with a force impact-measuring instrument. The sensitivity of the obstacle detection may be adjusted gradually to the door (see programming instructions). The anti-crushing device operation must be checked after each manual adjustment. Manual modification of the force can only be done by qualified personnel by performing the measurement test according to EN 12445. Modifications to the force adjustment must be documented in the machine manual.

⚠ **WARNING** The compliance of the internal sensing obstacles device to requirements of EN12453 is guaranteed only if used in conjunction with motors fitted with encoders.

⚠ **WARNING** Any external security devices used for compliance with the limits of impact forces must be conform to standard EN12978.

♻ **WARNING** In compliance with EU Directive 2012/19/EU on waste electrical and electronic equipment (WEEE), this electrical product should not be treated as municipal mixed waste. Please dispose of the product and bring it to the collection for an appropriate local municipal recycling.

**EVERYTHING THAT IS NOT EXPRESSLY PROVIDED FOR IN THE INSTALLATION MANUAL IS NOT ALLOWED. CORRECT OPERATOR OPERATION IS ONLY ENSUED WHEN THE REPORTED DATA IS RESPECTED. THE COMPANY DOES NOT RESPOND FOR DAMAGE CAUSED BY FAILURE TO COMPLY WITH THE INSTRUCTIONS CONTAINED IN THIS MANUAL. WITHOUT AFFECTING THE ESSENTIAL FEATURES OF THE PRODUCT, THE COMPANY RESERVES THE RIGHT TO MAKE ANY CHANGES DEEMED APPROPRIATE AND AT ANY TIME IN ORDER TO TECHNICALLY, STRUCTURALLY AND COMMERCIALY IMPROVE THE PRODUCT WITHOUT BEING REQUIRED TO UPDATE THIS DOCUMENT.**

## 2 PRODUCT DESCRIPTION

NET24N is a universal control panel for **DEA** System 1 or 2 24V  $\equiv$  operators automations with or without encoder.

The main feature of this control board is its ease of configuration of inputs and outputs according to any needs thus ensuring adaptability to any type of automation. It is therefore easy to set up and exclude all unnecessary functions.

## 3 TECHNICAL DATA

	TYPE 00			TYPE 01		TYPE 02	TYPE 03	
	Livi 6/24N	Livi 9/24N	REV	GEKO	ANGOLO Ghost 100/200 LOOK - MAC - STING LIVI 500/502 550PL	Livi 902/24 Livi 905/24	PASS	STOP
								4+5 m $\geq$ 6 m
<b>Power supply (V)</b>	230 V $\sim$ $\pm$ 10% (50/60 Hz)							
<b>Rated power transformer (VA)</b>	80 VA (230/22V)	250 VA (230/22V)	120 VA (230/22V)	150 VA (230/22V)		150 VA (230/22V)	250 VA* (230/22V)	
<b>Fuse F1 (A) (transformer)</b>	1A		2A				3,15A*	
<b>Batteries</b>	2x 12V 1,3A			2x 12V 1,3A		2x 12V 4A		
<b>Fuse F2 (A) (batteries input)</b>	15A							
<b>Outputs 24V <math>\equiv</math> motors (maximum output current) (A)</b>	1x 5A	1x 10A	2x 5A			2x 5A	2x 7A*	
	<b>Warning:</b> The above values are calculated by taking the maximum power supplied by the respective processors. In absolute terms, the maximum current for each output should not exceed 10A when using a single motor and 7A when using 2 motors.							
<b>Auxiliaries power supply output</b>	24 V $\equiv$ (24V_AUX + 24V_ST = max 200mA)							
<b>Stabilized power supply output for safety devices</b>								
<b>"Warning" output</b>	+24 V $\equiv$ max 15 W							
<b>Electric lock output</b>	24V $\equiv$ max 5W or max 1 art. 110							
<b>Flashing light output</b>	24 V $\equiv$ max 15W							
<b>Operating temperature range (°C)</b>	-20 $\div$ 50 °C							
<b>Receiver frequency</b>	433,92 MHz							
<b>Transmitters type of coding</b>	HCS fix-code - HCS rolling code - Dip-switch - DART							
<b>Max remote controllers managed</b>	100							

\* Values for STOP with boom  $\geq$  6 m.

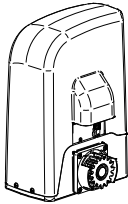
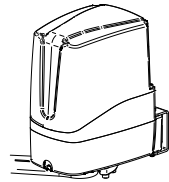
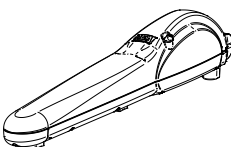
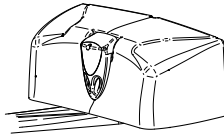
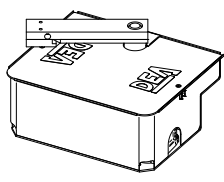
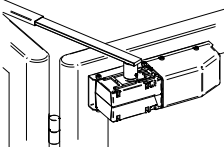
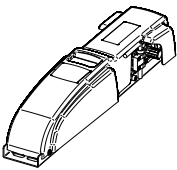
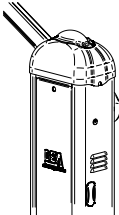
				
Livi N - Rev	Geko	Look - Mac - Sting	Livi 500 - Livi 502 - Angolo	Ghost 100 - Ghost 200
			* If you are not using <b>DEA</b> operators, set the parameter "Selection type of operator" to the closer value as family type and performances.	
Livi 550PL	Livi 902	Pass - Stop		

## 4 CONFIGURATION OF THE CONTROL PANEL

The universal control unit NET24N can be used for the management of the following types (TYPE) of closures motorized by DEA System: swing and sliding gates, overhead doors and barriers.

In order to ensure maximum adaptability to each TYPE of closure, the control board provides an initial procedure, performed only at the first turn, for the optimal configuration of inputs, outputs and parameters (see diagram A). Once configured, the control panel will operate in the mode "dedicated" to the TYPE of selected closing. After performing the initial configuration it is sufficient to execute the standard programming for the installation on which it is operating.

All settings remain in memory even in the case of subsequent flare-ups (see diagram B).

If necessary the TYPE of configured closing can be later adjusted following diagram C.

### FIRST CONTROL BOARD IGNITION

#### Configuration after the first ignition

**A** For the first control panel ignition, proceed as follows:

1. Apply power, the display shows in sequence the writing "rES-" and "TYPE" flashing;
2. Press the **OK** button and hold for 5 seconds until the display shows 0000 on the display;
3. Acting on the **+** and **-** keys, select the desired configuration depending on the type of installation (es. 0002) and confirm by pressing the **OK** button;  
At this point, the selection will be stored and reloaded each time in the future.
4. Follow signs, "TYPE", "-00-" followed by the symbol of closed gate "----".

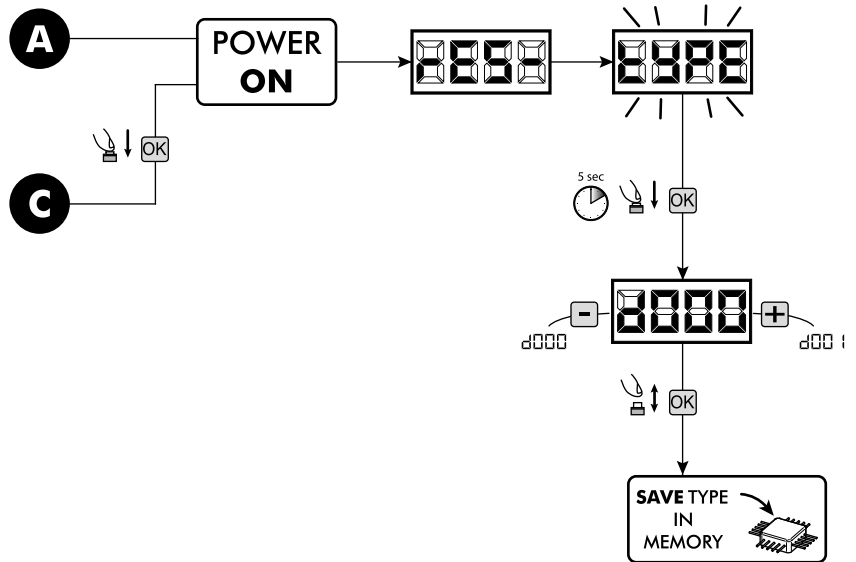

#### Following ignitions

**B** If you have already saved a configuration, proceed as follows:

Apply power, the display shows in sequence the writing "rES-", "TYPE", "-00-" followed by the symbol of closed gate "----".

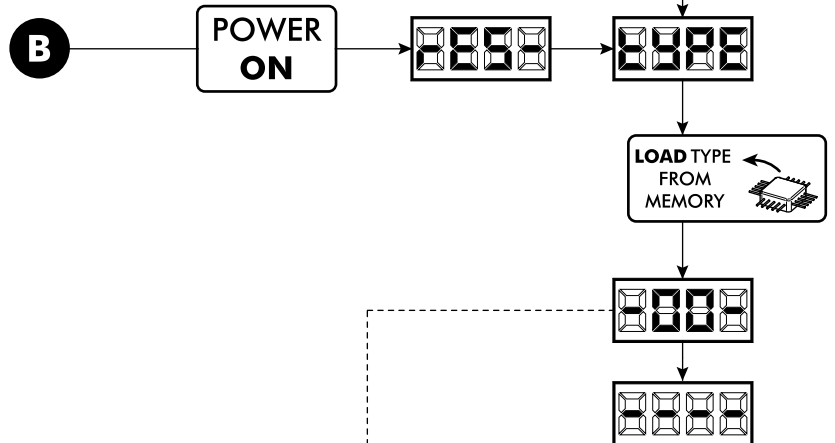

#### Modify the existing configuration

**C** If you have already saved a configuration and you want to change it, proceed as follows:

1. Hold down the **OK** button and give power, the display shows in sequence the writing "rES-" and "TYPE" flashing;
2. Press the **OK** button and hold for 5 seconds until the display shows 0000 (the value changes to match the previous configuration used) on the display;
3. Acting on the **+** and **-**, select the new desired configuration depending on the type of installation (es. 0002) and confirm by pressing the **OK** button;

⚠ Stop the reconfiguration procedure prior to confirmation, involves loading the previous configuration by the control panel without any modification.

⚠ However, if the reconfiguration procedure is brought to an end, the new configuration will take the place of the previous one and will be reloaded each time in the future.

4. Follow signs, "TYPE", "-00-" followed by the symbol of closed gate "----".

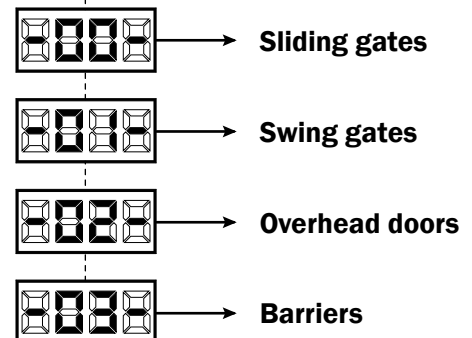

# 5 ELECTRICAL CONNECTIONS

Execute the wiring following the directions of table 1 and diagrams.

**WARNING** For adequate electrical safety, keep low safety voltage wires (controls, electro-locks, antenna, auxiliary power) clearly separate from 230V ~ power wires (**minimum 4 mm in air or 1 mm via supplementary insulation**) placing them in plastic raceways and securing them with adequate clamps near terminal boards.

**WARNING** For connection to the mains, use a multipolar cable having a minimum section 3x1,5 mm<sup>2</sup> and complying with the current regulations. For connecting the motors, use a minimum cross section 1,5 mm<sup>2</sup> cable and complying with the current regulations. As an example, if the cable is out side (outdoor), must be at least equal to H07RN-F, whereas if it (in a raceway), must be at least equal to H05VV-F.

**WARNING** All wires must be striped and unsheathed in the immediate vicinity of terminals. Keep wires slightly longer to subsequently eliminate any excess.

**WARNING** To connect the encoder to the control panel, use only a dedicated cable ≥ 3x0.25mm<sup>2</sup>.

Table 1 “terminal board connections”

<b>3-4</b>	22 V ~	22 V ~ transformer power supply input				
<b>5-6</b>	24VBatt	24 V === battery power supply or photovoltaic accumulator Green Energy input (follow carefully polarity indications).				
<b>7-8</b>		Operator 1 output				
<b>9</b>		Connection of motors metallic parts				
<b>10-11</b>		Operator 2 output (if present)				
<b>12-13</b>		24 V === max 15 W output for open gate fix warning light (if P052=0), flashing (if P052=1) or courtesy light (if P052>1)				
<b>14-15</b>		14 (+)	“Boost” output for electric-lock, max 1 x art. 110 (if P062=0), 24V pulse output, max 5W (if P062=1), step by step (if P062=2), electro-brake output for not self-locking operators (if P062=3), output for electric-lock power supply via external relay (if P062=4), output for electro-magnets power supply for barriers (ifP062=5) or temporized output (if P062>5).			
		15 (+)				
<b>16-17</b>		24 V === Flashing light output max 15W art. AURA N				
		<b>TYPE 00</b>	<b>TYPE 01</b>	<b>TYPE 02</b>	<b>TYPE 03</b>	If the installation requires different commands and / or additional to the standard, you can configure each input to the required rate. <b>Refer to Chapter “Advanced Programming”</b> .
<b>If unused, short circuit</b>						
<b>18 - IN_6</b>	<b>Input 6</b>					
<b>19 - Com</b>		N.C.	N.C.	N.O.	N.O.	
<b>20 - IN_5</b>	<b>Input 5</b>					
<b>21 - Com</b>		N.C.	N.C.	N.O.	N.O.	
<b>22 - IN_4</b>	<b>Input 4</b>					
<b>23 - Com</b>		N.C.	N.C.	N.C.	N.O.	
<b>24 - IN_3</b>	<b>Input 3</b>					
<b>25 - Com</b>		N.C.	N.C.	N.C.	N.O.	
<b>26 - IN_2</b>	<b>Input 2</b>					
<b>27 - Com</b>		N.O.	N.O.	N.C.	N.C.	
<b>28 - IN_1</b>	<b>Input 1</b>					
<b>29 - Com</b>		N.O.	N.O.	N.O.	N.O.	
-		Aerial signal input				
-		Ground aerial input				
<b>32-33</b>		32 (+)	24 V === power supply output for auxiliary devices		<b>(AUX + ST)</b> = <b>max 200mA</b>	
		33 (-)				
<b>1-2</b>		1 (-)	Stabilized 24 V === power supply output for tested safety devices			
		2 (+)				
<b>J5</b>	<b>J9</b>	Encoder selection Jumper:				
		<ul style="list-style-type: none"> <li>• A position = operators with encoder (remind to set P029=0)</li> <li>• B position = operators without encoder (remind to set P029=1)</li> </ul>				

EN

# Basic scheme NET24N

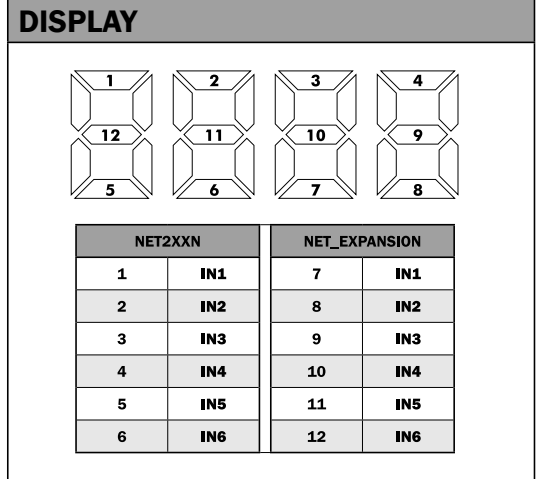
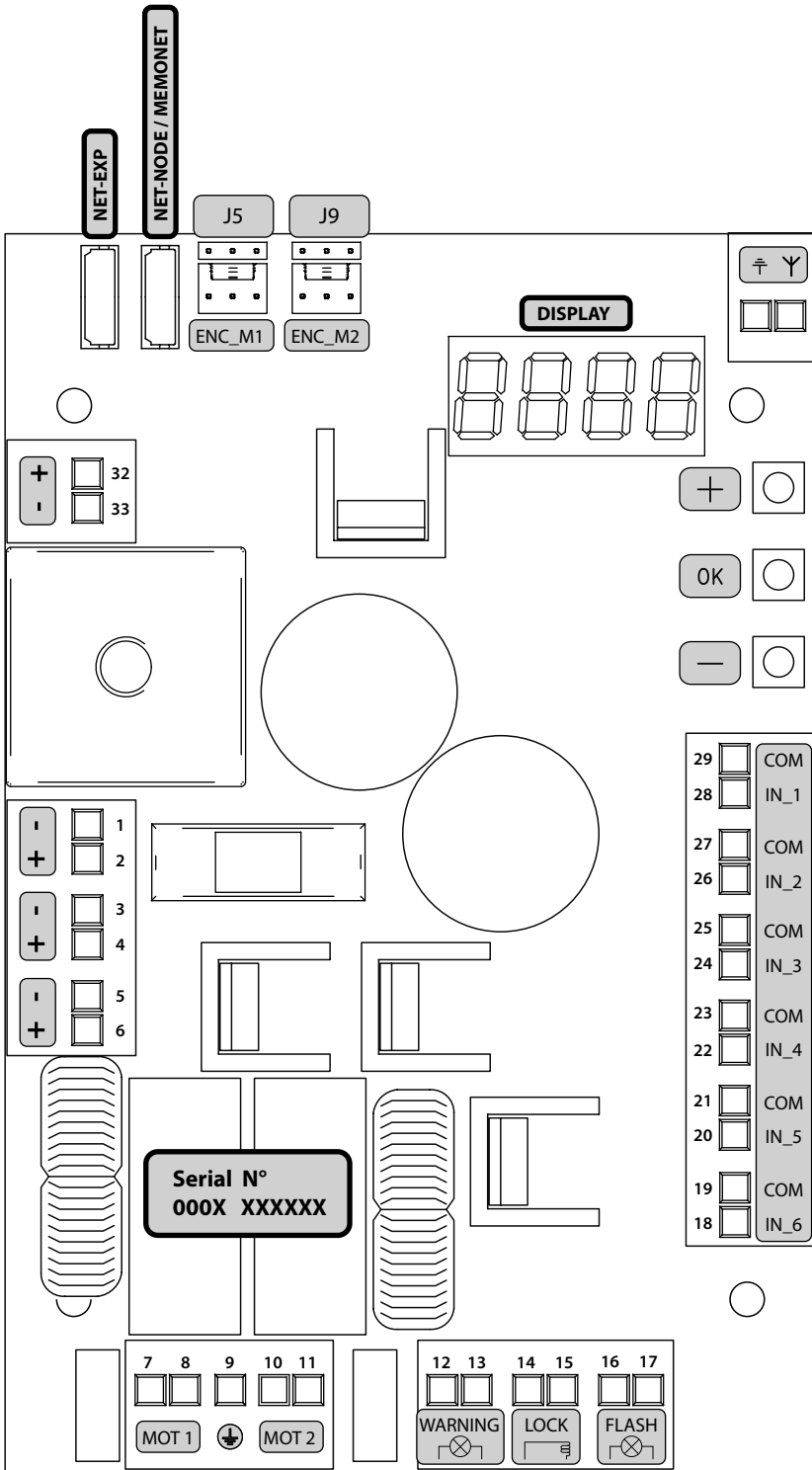

Wiring diagram for TYPE 00 (sliding gate)

INTERNAL WIRING SET BY THE FACTORY  
 EXTERNAL WIRING SET BY THE INSTALLER

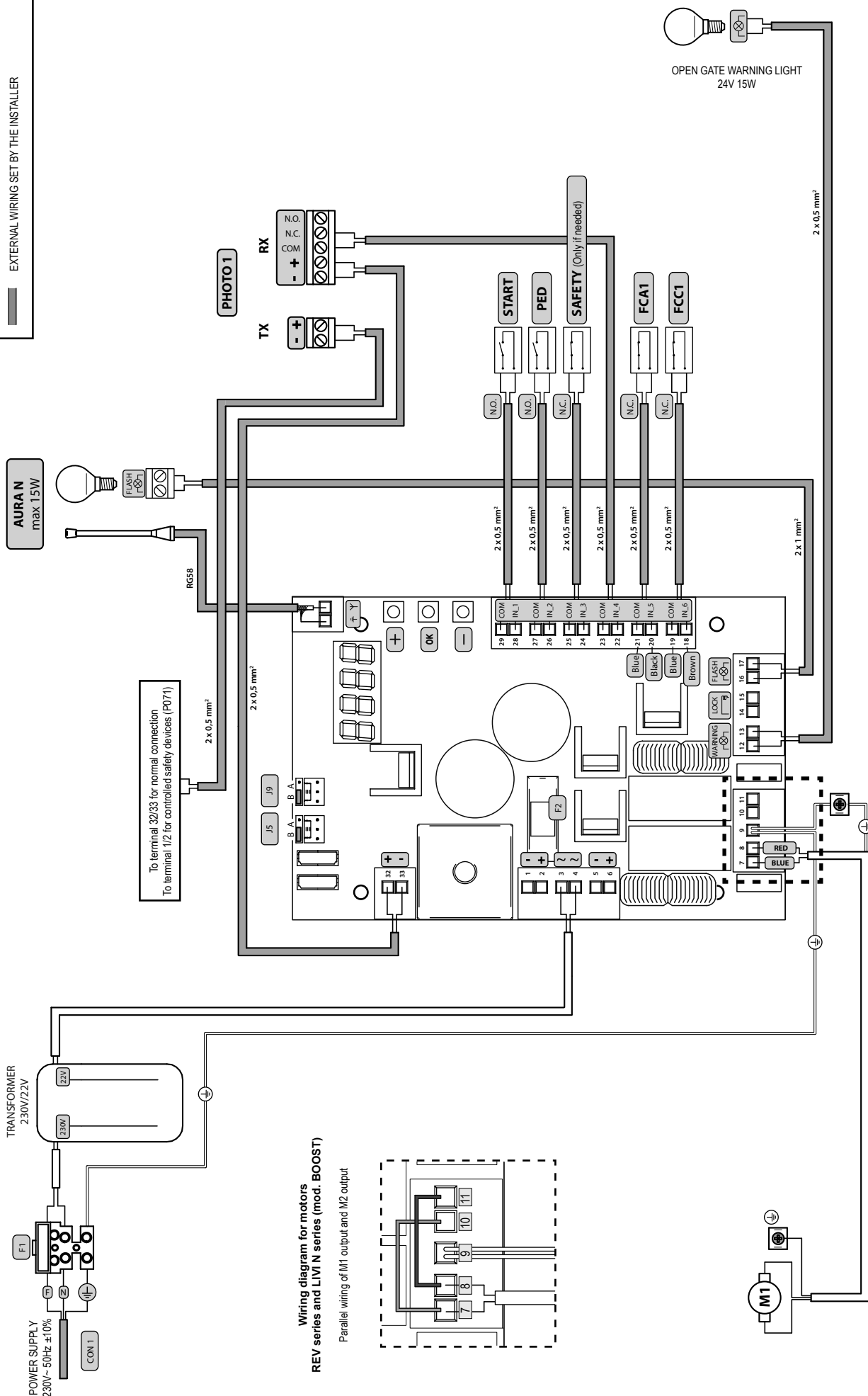

Wiring diagram for motors  
 REV series and LIVI N series (mod. BOOST)

Parallel wiring of M1 output and M2 output

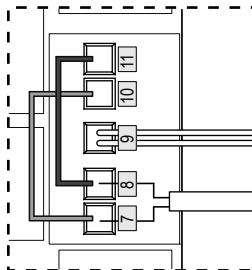

Wiring diagram for TYPE 01 (swing gate)

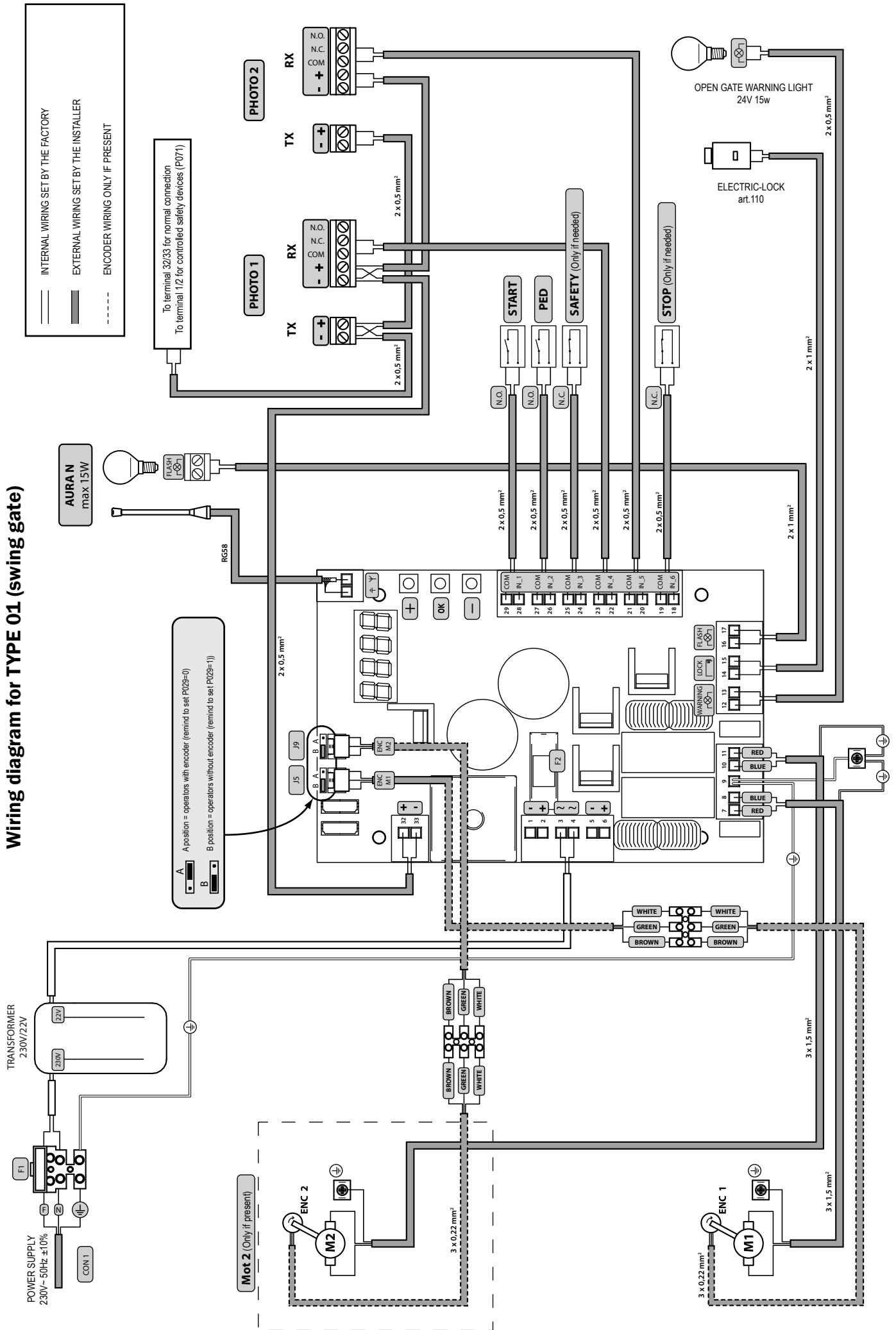

Wiring diagram for TYPE 02 (garage door)

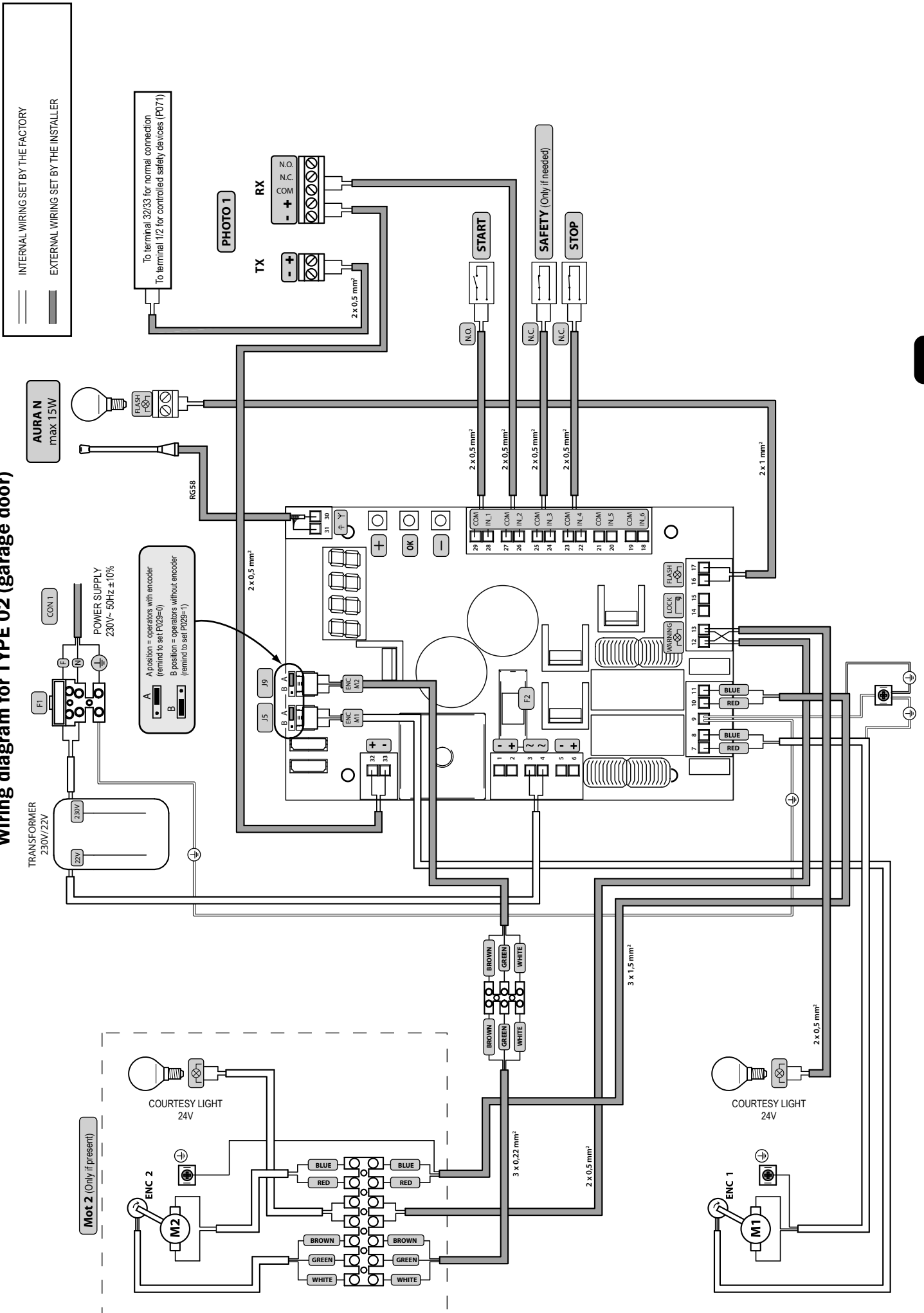



# 6 STANDARD PROGRAMMING

## 1 Power Supply

When turned on, "rES-", "0042" (or the current firmware version) "TYPE", "-0 1-" (or the selected Type) appear on the display in sequence followed by the closed gate symbol "----".

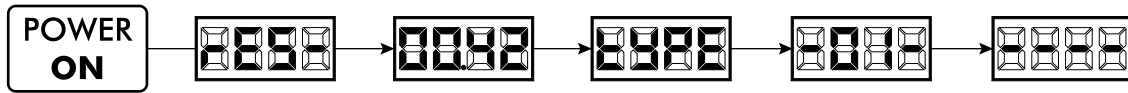

\* If the control panel has already been programmed and the power fails or is switched off - once power is returned and a START command is given, the position reset procedure is performed (see "rESP" in the table "WORKING STATUS MESSAGES" on page EN-18).

## 2 Visualisation of inputs and operations-counter status

1. Scroll the parameters with the **+** and **-** keys until the screen reads P013;
2. Access the parameter by pressing the **OK** button;
3. The "Input Status" is shown on the screen (check that this is correct):



4. Press the **OK** button again;
  5. The "Total Operation Counter" **TCYC** appears on the screen followed by the **PLU** multiplier.
- To calculate the number of completed operations, the two values must be multiplied.
- I.e.:**  $TCYC = 120 \times 10 = 1200$  operations completed

6. Press the **OK** button again;
  7. The "Total Maintenance Counter" **MCYC** appears on the screen followed by the **PLU** multiplier.
- To calculate the number of operations remaining before the maintenance request, the two values must be multiplied.
- I.e.:**  $MCYC = 1500 \times 1 = 1500$  operations yet to be completed before the maintenance request
8. Press the **OK** button again to exit the parameters (P013 is shown on the screen again).

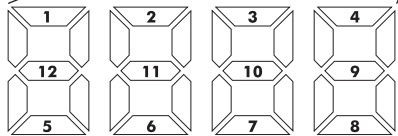
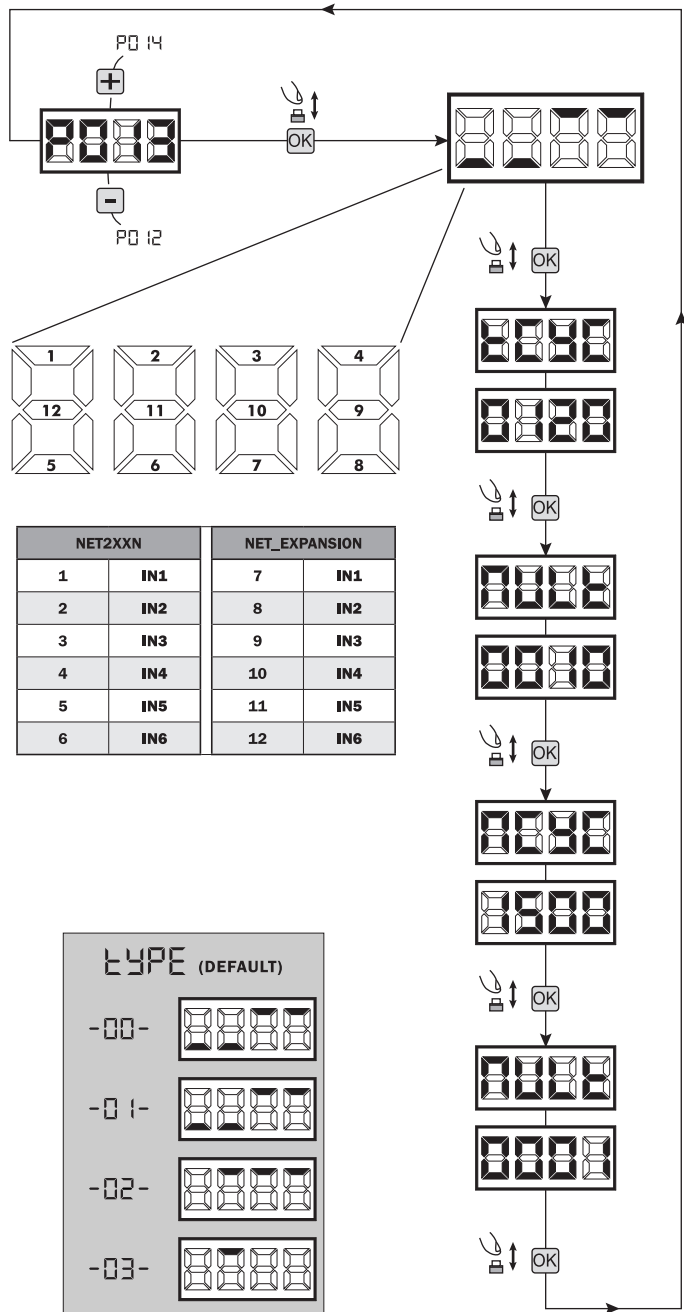

NET2XXN		NET_EXPANSION	
1	IN1	7	IN1
2	IN2	8	IN2
3	IN3	9	IN3
4	IN4	10	IN4
5	IN5	11	IN5
6	IN6	12	IN6

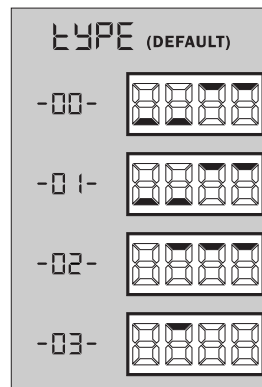

EN

### 3 Selection type of operators

# ! IMPORTANT !

1. Scroll down the parameters with **+** and **-** keys until you visualise P028;
2. Access the parameter by pressing the **OK** key;
3. Acting on **+** and **-** keys, set:

Type 00	Type 01	Type 02	Type 03
<ul style="list-style-type: none"> <li>• 005 5/24</li> <li>• 006 8/24</li> <li>• 007 Rev</li> </ul>	<ul style="list-style-type: none"> <li>• 000 Geko</li> <li>• 001 Look - Mac - Sting</li> <li>• 002 Ghost</li> <li>• 003 Livi 500 - 502 - 550PL - Angolo</li> </ul>	<ul style="list-style-type: none"> <li>• 003 Livi 902/24 - 905/24</li> </ul>	<ul style="list-style-type: none"> <li>• 003 Pass</li> <li>• 004 Stop</li> </ul>

**Warning:** If you are using non **DEA** System operators, set the parameter on the closer value for family type and performances (refer to table on page EN-3).

4. Confirm your choice by pressing the **OK** key (display returns again to P028).

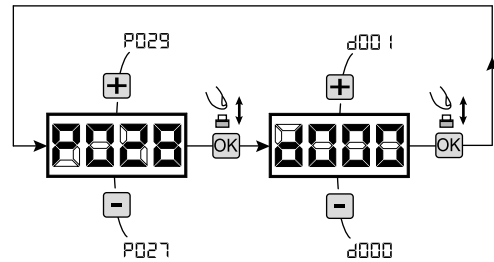

### 4 Selection operating with or without encoder

# ! IMPORTANT !

**Warning:** Remember to correctly set the jumpers J5 and J9.

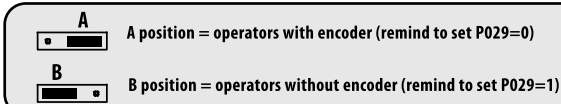

1. Scroll down the parameters with **+** and **-** keys until you visualise P029;
2. Access the parameter by pressing the **OK** key;
3. Acting on **+** and **-** keys, set:
  - d000=for operators with encoder;
  - d001=for operators without encoder;
4. Confirm your choice by pressing the **OK** key (display returns again to P029).

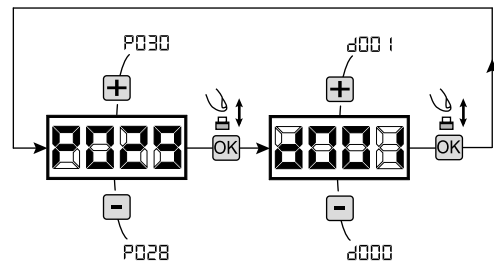

### 5 Selection 1 or 2 operators functioning

1. Scroll down the parameters with **+** and **-** keys until you visualise P030;
2. Access the parameter by pressing the **OK** key;
3. Acting on **+** and **-** keys, set:
  - d001=for a single motor operating;
  - d002=for 2 motors operating;
4. Confirm your choice by pressing the **OK** key (display returns again to P030).

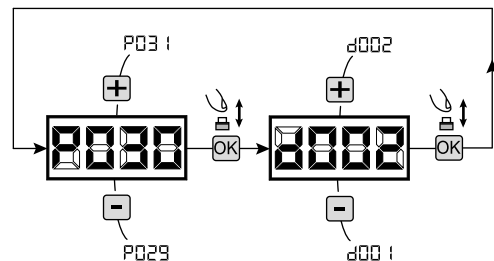

### 6 Selection of direction of motion (only Type 00 and Type 03)

1. Scroll down the parameters with **+** and **-** keys until you visualise P063;
2. Access the parameter by pressing the **OK** key;
3. Acting on **+** and **-** keys, set:
  - d000=motor in standard position;
  - d001=motor in inverted position;
4. Confirm your choice by pressing the **OK** key (display returns again to P063).

**Warning:** The parameter automatically reverses the motors output open/close.

**Warning:** Changing this parameter you need to change the parameters for the opening and closing limit switches.

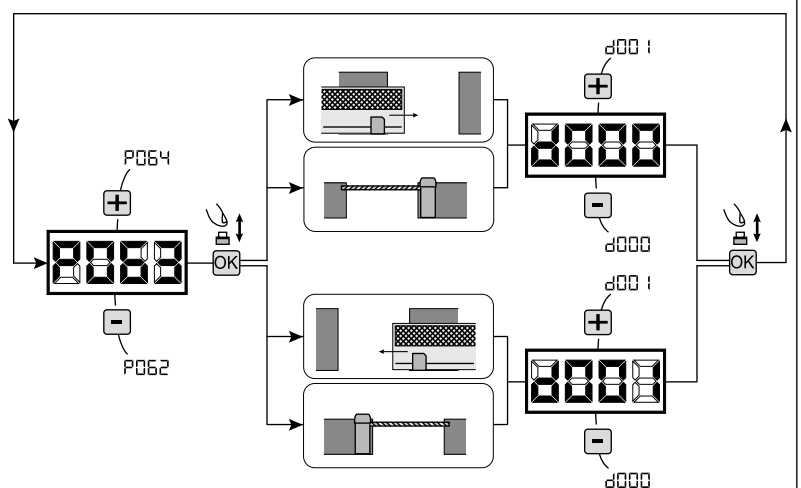



## 9.2 Learning

1. Scroll down the parameters with **+** and **-** keys until you visualise P005;
2. Confirm by pressing on the **OK** key;
3. When the symbol "LER" appears, press on any key of the transmitter you want to memorize;
4. The display visualizes the number of the transmitter just memorized and then "LER";
5. Memorize all necessary transmitters repeating this procedure from step 3;
6. Wait 10 seconds before quitting the memorization mode, display shows now "----".

**Warning:** In the case of rolling code remotes, the receiver can be put into learning mode by pressing the hidden button on a remote control previously learned.

**Warning:** When using personalized transmitters, after entering P005 the learning of the first personalized transmitter is possible only by pressing its hidden button. Afterwards, only transmitters personalized with the same encryption key can be memorized (through the usual procedure), unless a memory reset is carried out (P004).

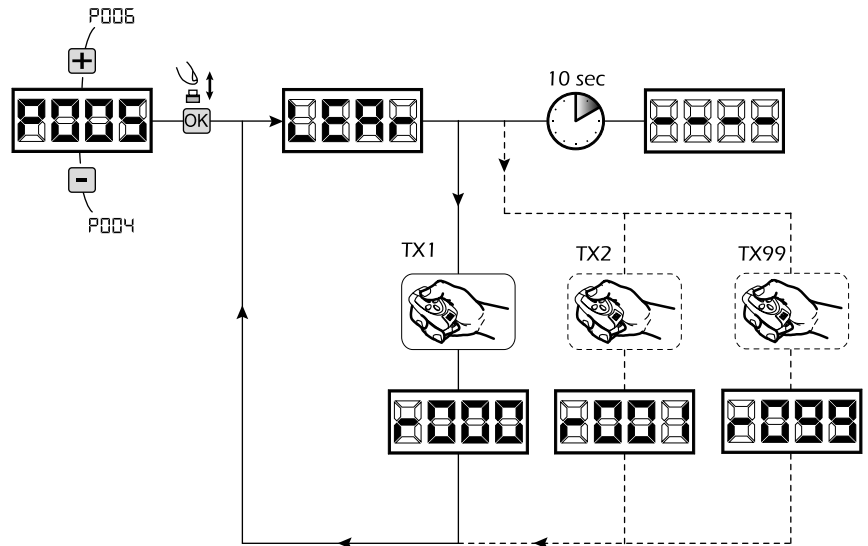

## 10 Adjustment of operating parameters

If you need to modify the operating parameters (force, speedness etc.):

1. Scroll down the parameters until you visualize the desired parameter (i.g. P032);
2. Confirm by pressing on the **OK** key;
3. By pressing on **+** and **-**, set up the desired value;
4. Confirm by pressing on the **OK** key (display shows the parameters previously selected).

**For the complete list of the "Operating Parameters" See the table on page. EN-22.**

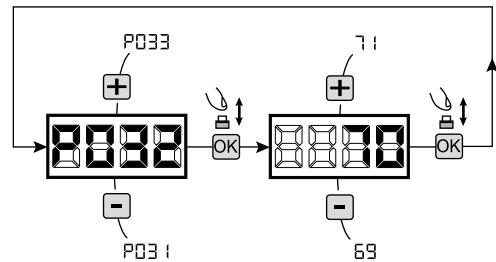

## 11 Programming complete

**WARNING** At the end of the programming procedure, use the buttons **+** and **-** until the appearance of the symbol "----", the operator is now ready again for new manoeuvres.

To perform any "Advanced Programming" operations (cancellation of the remotes, configuration inputs, etc. ..), see on page EN-15.

## 7 ADVANCED PROGRAMMING

Here are some added programming procedures relating to remotes memory management and advanced configuration of the control inputs.

### 1 Deletion of memorized transmitters

#### 1.1 Deletion of all transmitters

1. Scroll down the parameters until you visualize P004;
2. Confirm by pressing on the **OK** key;
3. When "E P n E" is flashing, press the **OK** key for a few seconds;
4. Release the **OK** key as soon as "E P n E" stops flashing;
5. All memorized transmitters have been deleted (display shows again P004).

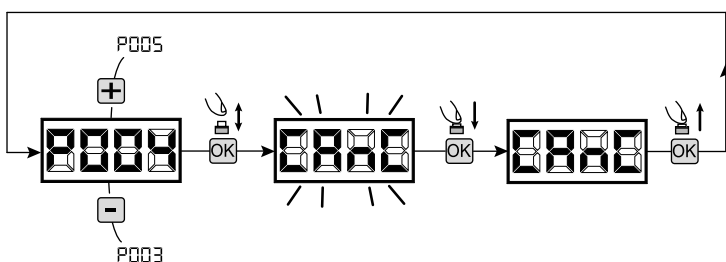

#### 1.2 How to search and delete a transmitter

1. Scroll down the parameters until you visualize P006;
2. Confirm by pressing on the **OK** key;
3. By pressing on **+** and **-** keys, select the transmitter you want to delete (eg. r 003);
4. When "r 003" flashes, confirm the deletion by pressing the **OK** key for a few seconds;
5. Release the **OK** key when appears "r - - -";
6. The selected transmitter is deleted (display shows again P006).

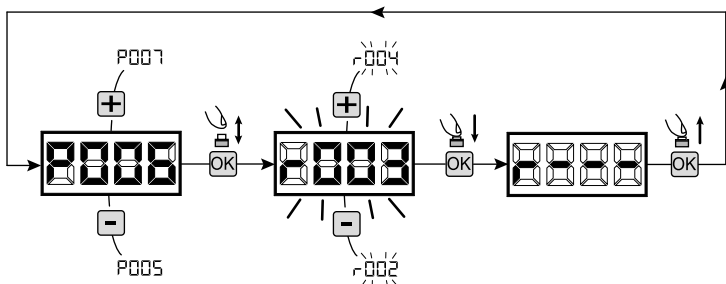

### 2 Restoring default parameters

#### 2.1 Restoring operating parameters

1. Scroll through the parameters with the buttons **+** and **-** until the display shows P007;
2. Confirm by pressing on the **OK** key;
3. When "dEF l" is flashing, press the **OK** key for a few seconds;
4. Release the **OK** key as soon as "dEF l" stops flashing; All the default values are restored except for the parameters from P016 to P022 and P076 to P098 for the configuration currently in use;
5. At the end of the operation display returns to P007.

**Warning:** After you restore the default parameters, you must program the control panel again and adjust all operating parameters, in particular, remember to properly set the operator configuration parameters. (P028 - P029 - P030).

**Warning:** For reversible motors with electro-brake, remember to set P062 = 3 at the end of the procedure.

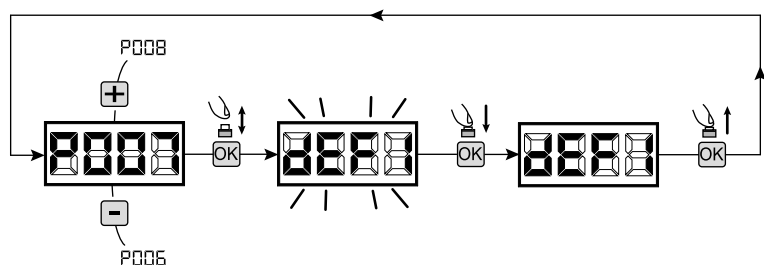

#### 2.2 Restoring "I/O" setting (Input/Output)

1. Scroll through the parameters with the buttons **+** and **-** until the display shows P010;
2. Confirm by pressing on the **OK** key;
3. When "dEF 2" is flashing, press the **OK** key for a few seconds;
4. Release the **OK** key as soon as "dEF 2" stops flashing; All the default values only for the parameters from P016 to P022 and from P076 to P098 are restored for the configuration currently in use;
5. At the end of the operation display returns to P010.

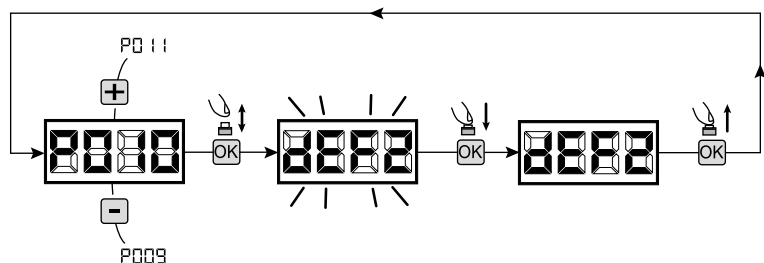

### 3 Locking-Unlocking access to programming

By using a “dip-switch” remote (regardless of the type of remotes already memorized) it's possible to lock-unlock access to the programming of the control panel to avoid tampering. The remote setting is the locking-unlocking code verified by the control board.

#### 3.1 Locking access to programming

1. Scroll through the parameters with the buttons  $\oplus$  and  $\ominus$  until the display shows P008;
2. Access the parameter by pressing the button  $\text{OK}$ ;
3. The display shows alternately the writing  $P_r008/F_rEE$  to indicate that the control board is waiting for the transmission of the block code;
4. Within 10 seconds press CH1 on the “TX Master”, the display shows  $P_r008/bL0C$  before returning to the list of parameters;
5. Access to programming is locked.

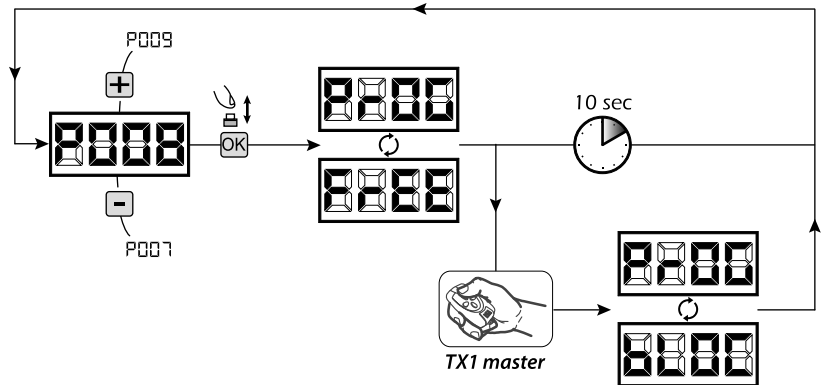

**WARNING** Programming lock/unlock can also be set via Smartphone using the DEAIstaller APP. In this case, an installer code is set (other than zero) that can only be unlocked via APP.

#### 3.2 Unlocking access to programming

1. Scroll through the parameters with the buttons  $\oplus$  and  $\ominus$  until the display shows P008;
2. Access the parameter by pressing the button  $\text{OK}$ ;
3. The display shows alternately the writing  $P_r008/bL0C$  to indicate that the control board is waiting for the transmission of the unlocking code;
4. Within 10 sec. press the CH1 of the “TX Master”, the display shows  $P_r008/F_rEE$  before returning to the list of parameters;
5. Access to programming is unlocked.

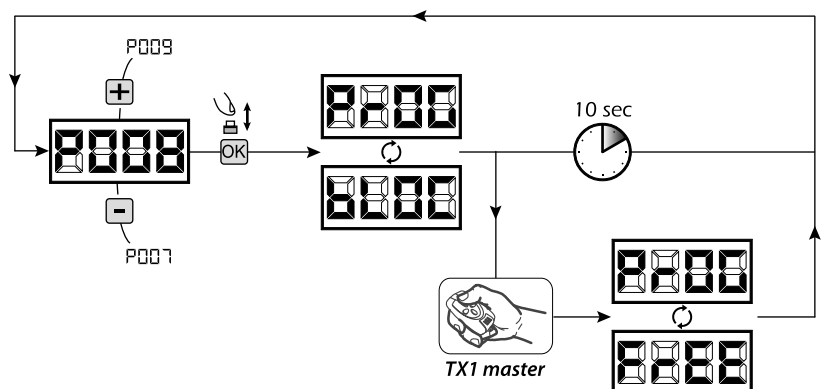

#### 3.3 Unlocking access to programming and global reset

**WARNING! This procedure involves the loss of all stored settings.**

The procedure allows the unlocking of the control panel without having to know its unlocking code.

Following this release, you must program the control panel again and adjust all operating parameters, in particular, remember to properly set the configuration of parameters (P028 - P029 - P030 - operator configuration). You will also need to repeat the measurement of impact forces to ensure the installation compliance to standards.

1. Scroll through the parameters with the buttons  $\oplus$  and  $\ominus$  until the display shows P008;
2. Access the parameter by pressing the button  $\text{OK}$ ;
3. The display shows alternately the writing  $P_r008/bL0C$ ;
4. Press the button  $\text{OK}$ , the display shows the flashing writing  $F_rEE$  ;
5. Press the button again and hold for 5 seconds (releasing it before, the procedure is terminated): The display shows the fixed writing  $F_rEE$  followed by  $dEF \uparrow$ , before returning to the list of parameters;
6. Access to programming is unlocked.

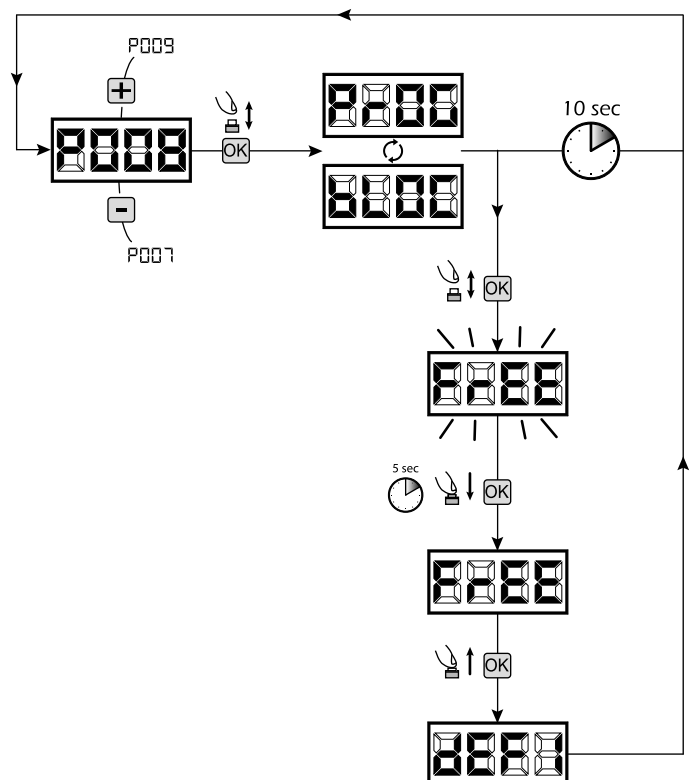

## 4 Downloading/uploading data memory

### 4.1 Downloading data to an external memory unit (DOWNLOAD)

1. Scroll down the parameters with **+** and **-** keys until you visualize P011;
2. Press the **OK** key, the display visualizes the word “dnl d” flashing;
3. Press the **OK** again and continue pressing it for 5 sec (if you release it before this period, the procedure is stopped);
4. Release the **OK** key as soon as the word “dnl d” stops flashing;

All the control panel configurations (TYPE, parameters, remotes, operators stroke, etc..) are saved in the external memory unit;

**Warning:** If there is any data in the external memory, during the memory download they will be overwritten.

5. At the end of the operation display returns to P011.

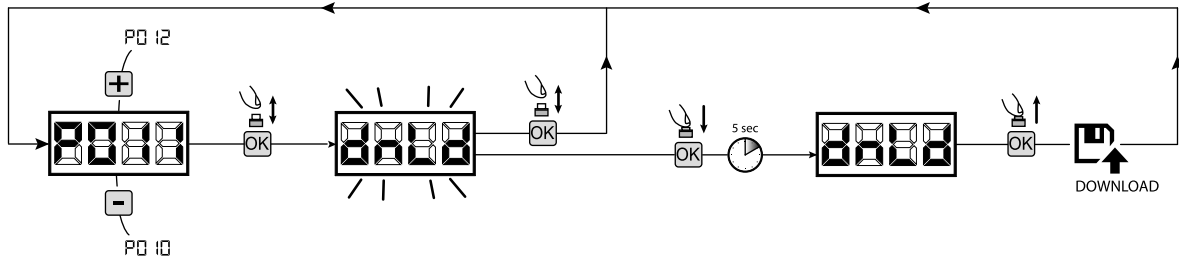

### 4.2 Uploading data from an external memory unit (UPLOAD)

1. Scroll down the parameters with **+** and **-** keys until you visualize P012;
  2. Press the **OK** key, the display visualizes the word “lpl d” flashing;
  3. Press the **OK** again and continue pressing for 5 sec (if you release it before this period, the procedure is stopped);
  4. Release the **OK** key as soon as the word “lpl d” stops flashing;
- All the control panel configurations (TYPE, parameters, remotes, operators stroke, etc..) contained in the external memory unit are uploaded in the connected control panel;
5. At the end of the operation display returns to P012.

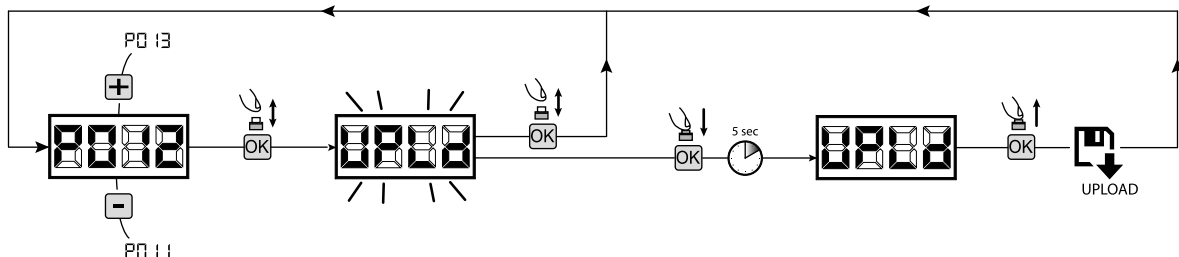

**WARNING** If you are not connected to any external storage units or if the connecting cable is disconnected during the data transfer operation, the display will visualize  $\text{E r r}$ , then the control unit is entirely reset and the display shows the word “TYPE” flashing. Refer to the instruction of the external memory card to restore the operation of the control panel.

## 5 Inputs configuration

Where the installation requires different commands and / or additional to the standard ones described by plan, you can configure each input for the operation desired (eg START, PHOTOS, STOP, etc ...).

1. Scroll down the parameters with the **+** and **-** to see that corresponding to the desired one:
  - P017=for INPUT 1;
  - P018=for INPUT 2;
  - P019=for INPUT 3;
  - P020=for INPUT 4;
  - P021=for INPUT 5;
  - P022=for INPUT 6;
2. Confirm by pressing on the **OK** key to get access to the parameter (eg. P018);
3. Scroll down with the **+** and **-**, keys to set the value corresponding to the desired operation (refer to table “Input Configuration parameters” on page EN-20);
4. Confirm by pressing on the **OK** key (display shows again P018).
5. Execute the new connection to the input just reconfigured.

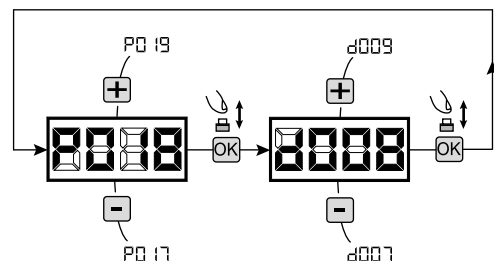

## 6 Programming complete

**WARNING** At the end of the programming procedure, use the buttons **+** and **-** until the appearance of the symbol “----”, the operator is now ready again for new manoeuvres.

## 8 MESSAGES SHOWN ON THE DISPLAY

WORKING STATUS MESSAGES		
Mess.	Description	
----	Gate is closed	
_   _	Gate is opened	
OPEN	Opening under way	
CLOS	Closing under way	
STEP	While in step-by-step mode, the control board awaits further instructions after a start command	
STOP	Stop input intervened or an obstacle is detected with limited inversion duration (P055 > 0 or P056 > 0)	
⌂ ⌂	Board in BOOT-MODE: Indicates that the firmware is corrupted or updating. To restore the firmware, use the DEAIstaller APP and make sure NET-NODE is corrected to the correct port. <b>Warning: When updating the firmware, all data in the board memory (settings and radio commands) are lost. Make sure you have backed up the memory to be restore data after the update.</b>	
RESP	Reset current position: The control unit has just been turned on after a power failure, or the gate has exceeded the maximum number (80) of inversions allowed without ever getting to the closing stroke, or the maximum number (15) of consecutive operations allowed of the anti-crushing device. Once the control unit has been reset and open command given the gate will start moving at slow speed, until it reaches end of travel.	
ERROR MESSAGES		
Mess.	Description	Possible solutions
ERRP	Error position: The reset position procedure is not successful. The control panel is awaiting commands.	<ul style="list-style-type: none"> <li>- Make sure there are no specific frictions and / or obstacles during the run;</li> <li>- Give a start pulse to initiate a position reset procedure;</li> <li>- Verify that the operation is completed successfully, manually helping the run, if necessary;</li> <li>- Adjust power and speed settings if necessary.</li> </ul>
BLDC UART	Board programming attempted when a NET-NODE device is connected.	Turn off power, disconnect the NET-NODE from the communication port and turn back on;
ERR3	External photocells and/or safety devices are activated or out of order.	- Make sure that all safety devices and/or photocells installed are working properly.
ERR4	Possible fault/overheating in the control unit's power circuit.	Turn off power for several minutes and turn back on. Give a start command: if the message is repeated, replace the control unit.
ERR5	Time-out operators run: The engine/s exceeded the maximum operating time (4min) without ever stopping.	<ul style="list-style-type: none"> <li>- Give a start pulse to start the position reset procedure;</li> <li>- Ensure that this operation is successful.</li> </ul>
ERR6	Time-out obstacle detection: With anti-crushing sensor disabled, was still detected the presence of an obstacle that prevents movement of the leaf for a period of 10 seconds more.	<ul style="list-style-type: none"> <li>- Make sure there are no specific frictions and / or obstacles during the run;</li> <li>- Give a start pulse to initiate a position reset procedure;</li> <li>- Verify that the operation is completed successfully.</li> </ul>
ERR7	Operators movement not detected.	<ul style="list-style-type: none"> <li>- Make sure that operators and encoders connections are well done.</li> <li>- Check that jumpers J5 and J9 are well positioned as shown on the electric wiring.</li> <li>- If this error appears again, replace the control panel.</li> </ul>
ERR9	No/interrupted communication with remote memory board (also NET-EXP or NET-NODE).	<ul style="list-style-type: none"> <li>- Check that the connecting cable of the external memory card is connected properly.</li> <li>- If you are performing a data transfer operation (DOWNLOAD / UPLOAD), make sure that it is not interrupted (eg by unplugging the card before the end of the operation).</li> </ul> <p><b>Please note:</b> the interruption of an UPLOAD, also involves a total RESET of the control unit.</p>
Err 10 Err 11	Possible fault/overheating in the control unit's power circuit.	Turn off power for several minutes and turn back on. Give a start command: if the message is repeated, replace the control unit.
Err 12	Possible malfunction in the control unit's power circuit or in the encoder circuit.	<p>Check the wiring of the encoder and the motor. Shut the power supply off and on again. Give a start command: if the message is repeated, perform the following checks.</p> <ul style="list-style-type: none"> <li>- Enter P003 and move the door using the + and - buttons.</li> <li>- If the door moves at maximum speed and the display shows Err7, replace the motor's encoder card.</li> <li>- If the motor still remains stationary, replace the control unit.</li> </ul>
Err 15	Sensitive regulation parameters were edited via DEAIstaller APP without running motor stroke learning at the end of the operation.	Run motor stroke learning (P003) first to be able to run any other operation.
Err 1	NET-NODE connected to the incorrect communication port.	Connect NET-NODE to the correct port according to that indicated in the control unit diagram.

## 9 INSTALLATION TEST

The testing operation is essential in order to verify the correct installation of the system. **DEA** System wants to summarize the proper testing of all the automation in 4 easy steps:

- Make sure that you comply strictly as described in paragraph 2 “WARNINGS SUMMARY”;
- Test the opening and closing making sure that the movement of the leaf match as expected. We suggest in this regard to perform various tests to assess the smoothness of the gate and defects in assembly or adjustment;
- Ensure that all safety devices connected work properly;
- Perform the measurement of impact forces in accordance with the standard 12445 to find the setting that ensures compliance with the limits set by the standard EN12453.

## 10 PRODUCT DISPOSAL

 **WARNING** In compliance with EU Directive 2012/19/EU on waste electrical and electronic equipment (WEEE), this electrical product should not be treated as municipal mixed waste. Please dispose of the product and bring it to the collection for an appropriate local municipal recycling.

	PAR.	PROCEDURE
<b>PROGRAMMING PROCEDURES</b>	P001	Positioning of operator 1
	P002	Positioning of operator 2
	P003	Memorization of the motors' stroke
	P004	Deletion of transmitters
	P005	Transmitters memorizing
	P006	Search and deletion of a transmitter
	P007	Restoring the operating parameters
	P008	Lock access to programming
	P009	How to learn connected DE@NET devices (unused at the moment)
	P010	Restoring the "I/O" configurations (input/output)
	P011	Downloading data on the external memory unit
	P012	Uploading data from an external memory unit
	P013	Visualisation of inputs and operations-counter status
	P014	Unused parameter
	P015	Unused parameter

	PAR.	SETTABLE VALUES
<b>INPUTS CONFIGURATION PARAMETERS</b>	P016	INPUT_3 selectioning input type
	P017	INPUT_1 operating selection
	P018	INPUT_2 operating selection
	P019	INPUT_3 operating selection
	P020	INPUT_4 operating selection
	P021	INPUT_5 operating selection
	P022	INPUT_6 operating selection



INPUTS CONFIGURATION PARAMETERS	P023	Allocation of CHANNEL 1 of remotes
	P024	Allocation of CHANNEL 2 of remotes
	P025	Allocation of CHANNEL 3 of remotes
	P026	Allocation of CHANNEL 4 of remotes
	P027	Selection of type of remotes
OPERATORS CONFIGURATION PARAMETERS	P028	Selection type of operators
	P029	Selected work with or without encoders. <u>CAUTION: Remember to correctly set the jumpers J5 and J9 (see table 1)</u> <u>WARNING: J5, J9 and P029 must be set correctly before performing the procedure for programming</u>
	P030	Selectioning operators number
OPERATING PARAMETERS	P031	Operators speed adjustment during slow-down while opening
	P032	Operators speed adjustment during the stroke while opening
	P033	Operators speed adjustment during the stroke while closing
	P034	Operators speed adjustment during slow-down while closing
	P035	Slow down duration adjustment while opening
	P036	Slow down duration adjustment while closing
	P037	Operator 1 force adjustment while opening (if = 100% obstacle detection deactivated)
	P038	Operator n.1 force adjustment while closing (if = 100% obstacle detection deactivated)
	P039	<b>TYPE 00 - 01 - 03 ONLY:</b> Operator n.2 force adjustment while opening (if = 100% obstacle detection deactivated)
		<b>TYPE 02 ONLY:</b> Secondary force adjustment in closing: adjusts the motor's force during the last part of the closing movement defined by P058
	P040	Operator n.2 force adjustment while closing (if = 100% obstacle detection deactivated)
	P041	Automatic closing times adjustment (if = 0 automatic closing deactivated)
	P042	Pedestrian automatic closing time adjustment (se = 0 pedestrian automatic closing deactivated)
	P043	Pedestrian stroke duration adjustment
	P044	Pre-flashing time adjustment
P045	Adjustment of phase displacement time while opening	
P046	Adjustment of phase displacement time while closing	
P047	Collectivity function: if it is activated it deactivates both opening and closing inputs for the whole duration of automatic opening and closing	

		TYPE 00	TYPE 01	TYPE 02	TYPE 03
<ul style="list-style-type: none"> <li>• 000: NONE (unused parameter)</li> <li>• 001: START (start)</li> <li>• 002: PEDESTRIAN (pedestrian)</li> <li>• 003: OPEN (separated open)</li> <li>• 004: CLOSED (separated close)</li> <li>• 005: Unused</li> <li>• 006: Unused</li> <li>• 007: ELOCK-IN (electric-lock activation. See P062)</li> <li>• 008: AUX_IN (with NET_EXP only)</li> <li>• 009: STOP</li> </ul>	<b>CH1</b>	001	001	001	001
	<b>CH2</b>	000	000	000	000
	<b>CH3</b>	000	000	000	000
	<b>CH4</b>	000	000	000	000
<ul style="list-style-type: none"> <li>• 000: HCS fix-code</li> <li>• 001: HCS rolling-code</li> </ul>	<ul style="list-style-type: none"> <li>• 002: Dip-switch</li> <li>• 003: DART</li> </ul>	000	000	000	000
<ul style="list-style-type: none"> <li>• 000: GEKO</li> <li>• 001: LOOK - MAC - STING</li> <li>• 002: GHOST 100/200</li> <li>• 003: 500 - 502 - 902 - PASS - 550PL - ANGOLO</li> <li>• 004: 502MT/24 - 902R/24 - STOP</li> </ul>	<ul style="list-style-type: none"> <li>• 005: LIVI 5/24</li> <li>• 006: LIVI 8/24</li> <li>• 007: REV</li> </ul>	005	000	003	003
<ul style="list-style-type: none"> <li>• 000: motors with encoder</li> <li>• 001: engines without encoder</li> </ul>		001	001	000	000
<ul style="list-style-type: none"> <li>• 001: one operator</li> <li>• 002: two operators</li> </ul>		001	002	001	001
15%tot.....100%tot		040	050	050	030
15%tot.....100%tot		100	100	100	100
15%tot.....100%tot		100	100	100	100
15%tot.....100%tot		040	050	050	030
0%tot.....80%to		025	020	020	030
0%tot.....80%tot		025	020	020	030
15%tot.....100%tot		050	050	050	099
15%tot.....100%tot		050	050	050	099
15%tot.....100%tot		050	050	000	099
0%tot.....100%tot					
15%tot.....100%tot		/	050	/	099
0sec.....255sec		000	000	000	000
0sec.....255sec		000	000	000	000
5%tot.....100%tot		030	035	035	100
0sec.....10sec		000	000	000	000
0sec.....30sec		/	001	/	/
0sec.....30sec		/	003	/	/
<ul style="list-style-type: none"> <li>• 000: disabled</li> <li>• 001: activated only upon opening</li> <li>• 002: activated on automatic opening and closing</li> </ul>		000	000	000	000

OPERATING PARAMETERS	P048	Ram blow function: if=0 "Ram blow" function deactivated; if=1 it pushes the motors closed for one second before each opening movement, so as to ease the releasing of any electric lock; if>1 it execute a periodic pushing stroke so as to maintain the wings under pressure on the closing strokes. If closing limit switches are installed, it performs this function only if they are not activated, i.g. when there's a pressure decrease on the stroke.	
	P049	"Reversal" mode selection (during the manoeuvre a command impulse reverse the mouvement) or "step by step" (during the manoeuvre a command impulse stops the mouvement). A next impulse restart the operator to the opposite direction.	
	P050	PHOTO 1	PHOTO input functioning: If=0: photocell enabled while closing and starting when the gate is stopped; if=1 photocells are always enabled; if=2 photocells are enabled while closing only. When enabled, its activation provokes: the inversion (while closing), the stop (while opening) and prevent the starting (when gate is closed). If = 3-4-5, the operation is identical to values 0-1-2 but with the "close immediately" function enabled: in any case, when opening and / or pausing time, removing a any obstacle the gate will end the opening maneuver before closing it automatically after a 2 second fixed delay.
	P051	PHOTO 2	
	P052	Operation mode selection of the warning light output: If = 0 "warning light" (output always ON when the gate is open, OFF after a closing operation), If = 1 "flashing warning light" (slow intermittent output during opening and fast while closing, always ON at gate opened, always OFF at the end of a closing operation only), If > 1 "courtesy light" (output ON during each movement, OFF when the motor stops, after the setting delay)	
	P053	Searches for end of stroke while opening too: when activated, operators stop only at their arrival et the end of stroke, also while opening. <b>Warning:</b> During the emergency operation (rESP), the motor executes the first maneuver while opening. In addition, if any limit switches, the parameter is forced to 1.	
	P054	"soft start" function: motors accelerate gradually until they reach the set speed, avoiding sudden departures <b>ONLY TYPE 02:</b> If=3 the opening slow space (P035) also becomes the space within which the port moves at slow speed (P031) and close start.	
	P055	Adjust the inversion on obstacle period (detected by internal anti-crushing sensor or by the safety input when activated): If = 0 it makes a complete inversion, if> 0 indicates the duration (in seconds) of the run, after inversion resulting from detection of an obstacle during the opening.	
	P056	Adjust the inversion on obstacle period (detected by internal anti-crushing sensor or by the safety input when activated): If = 0 it makes a complete inversion, if> 0 indicates the duration (in seconds) of the run, after inversion resulting from detection of an obstacle during the closing.	
	P057	Facilitation manual release: If≠0, after ending the closing or opening maneuver, the engine reverses for a brief time to release the pressure on it, and thus facilitate the manual release. The set value shows the length of the inversion. If=0 function disabled	
	P058	<b>TYPE 00 - 01 - 03 ONLY:</b> Adjustment of the opening stroke margin: it adjusts the duration of the last part of the stroke during which an obstacle is interpreted as a stroke, blocking the motor without performing the inversion. For motors with encoders, the set value indicates the number of revolutions of the rotor; while for motors without encoder, the value is expressed in% of the maximum stroke. <b>Warning:</b> for motors without encoder, if P035 (duration slow-down while opening) is >10%, it forces the stroke detection margin so that it's the same than the slow-down.	
		<b>TYPE 02 ONLY:</b> Duration adjustment for the secondary force in closing: adjusts the duration of the last part of the closing movement, in which the force is managed separately with P039. The value is expressed in number of revolutions of the rotor.	

	TYPE 00	TYPE 01	TYPE 02	TYPE 03
<ul style="list-style-type: none"> <li>• 000: "ram blow" deactivated</li> <li>• 001: "ram blow function" activated</li> <li>• &gt;001: "ram blow" periodic (X*1 min) (2.....255)</li> </ul>	000	000	000	000
<ul style="list-style-type: none"> <li>• 000: "reversal function"</li> <li>• 001: "step by step function"</li> </ul>	001	001	001	001
<ul style="list-style-type: none"> <li>• 000: photocell enabled while closing and when gate is stopped</li> <li>• 001: photocells always enabled</li> <li>• 002: photocells enabled only while closing</li> <li>• 003: as 000 but with "close immediately" enabled</li> <li>• 004: as 001 but with "close immediately" enabled</li> <li>• 005: As 002 but with "close immediately" enabled</li> </ul>	002	002	002	002
	000	001	002	002
<ul style="list-style-type: none"> <li>• 000: "fix warning light"</li> <li>• 001: "flashing warning light"</li> <li>• &gt;001 : "courtesy light" off delay (2sec.....255sec)</li> </ul>	000	000	050	000
<ul style="list-style-type: none"> <li>• 000: Stop when opening on a memorized point</li> <li>• 001: Stop when opening on the end of stroke</li> </ul>	/	000	001	001
<ul style="list-style-type: none"> <li>• 000: "soft start" deactivated</li> <li>• 001: "soft start" activated</li> <li>• 002: "long soft start" activated</li> <li>• 003: "settable soft start" on <b>(Type 2 only)</b></li> </ul>	001	001	001	001
<ul style="list-style-type: none"> <li>• 000: complete reversal on obstacle</li> <li>• &gt;000: duration of reversal on obstacle (1sec.....10sec)</li> </ul>	003	003	003	003
<ul style="list-style-type: none"> <li>• 000: complete reversal on obstacle</li> <li>• &gt;000: duration of reversal on obstacle (1sec.....10sec)</li> </ul>	003	003	003	003
<ul style="list-style-type: none"> <li>• 000: facilitating release disabled</li> <li>• &gt;000: facilitation activated with release time equal to: (1x25ms.....20x25ms) (1x25ms.....40x25ms) <b>(only Type 0)</b></li> </ul>	000	001	003	002
<p>1.....255 (motors with encoder) 1%.....100% (motors without encoder)</p>	012	025	000	020
0.....255				

OPERATING PARAMETERS	P059	<p><b>TYPE 00 - 01 - 03 ONLY:</b> Adjustment of the closing stroke margin: it adjusts the duration of the last part of the stroke during which an obstacle is interpreted as a stroke, blocking the motor without performing the inversion.</p> <p>For motors with encoders, the set value indicates the number of revolutions of the rotor; while for motors without encoder, the value is expressed in% of the maximum stroke.</p>
		<p><b>TYPE 02 ONLY:</b> Adjustment of the stop-margin in closing: adjusts the duration of the last part of the closing movement, in which an obstacle is seen as a stop, causing the motor to stop without reversal on the obstacle. The value is expressed in number of revolutions of the rotor.</p>
	P060	<p><b>TYPE 00 - 01 - 03 ONLY:</b> Operators force adjustment at stroke arrival - If=0, setting off (the force value on the stroke is calculated automatically) - If≠0 (operators with encoder) it indicates the force value (expressed in% of the max value) set in the last length.</p>
		<p><b>TYPE 02 ONLY:</b> Force adjustment in the stop margin in closing, its duration is set through P059.</p>
	P061	<p>“Energy saving” mode: If=1 after 10sec of inactivity, the control panel turns the 24V outputs and the display off that will be turned on at first command received (use recommended battery-powered and / or solar panel).</p> <p><b>Warning:</b> when “Energy saving” is enabled, SAS function is not available.</p> <p><b>Warning:</b> when “Energy saving” is enabled, only the stabilized output 24V_ST must be used to power accessories.</p>
	P062	<p>Electric-lock output operating: If=0 “boost” output for electric-lock art.110 power supply, If=1 24V output controlled by the ELOCK_IN input as pulsed mode, If=2 24V output controlled by the ELOCK_IN input as step-by-step mode, If=3 electro-brake output for not self-locking operators, If=4 24V output for electric-lock power supply via an external relay, If=5 24V output for electro-magnets power supply for barriers, If&gt;5 24V output controlled by the ELOCK_IN input as temporized mode (the set value indicates the switch-off delay in seconds).</p> <p><b>Warning:</b> To adjust the activation/deactivation times in the 000   004   005 modes, use parameter P064.</p>
	P063	<p>Run direction inversion: If=1 automatically reverses the outputs open/close of the operators, avoiding having to manual change the wiring when installing the operator in an inverted position.</p> <p><b>Warning:</b> Changing this parameter you need to change the parameters for the opening and closing limit switches.</p>
	P064	<p>Electric lock duration adjustment</p> <p>If P062=000   004, adjust the activation time of the LOCK output;</p> <p>If P062=005, adjust the deactivation time of the LOCK output;</p>
	P065	<p>Maintenance Operations-counter: if = 0 reset the counter and disables the intervention request , if&gt; 0 indicates the number of operations (x 500) to be made before the control panel executes a 4 second additional pre-flash to indicate the need of maintenance.</p> <p>i.g.: If P065 = 050, operations number = 50x500 = 25000 operations</p> <p><b>Warning:</b> Before you set a new value of the counter-manoeuvres maintenance, the same must be reset by setting P065= 0 and only later P065 = “new value”.</p>
	P066	<p>Selection of operating flashing light output: If=0 intermittent flashing light output;</p> <p>If=1 Fixed flashing light output (for flashing lights with intermittent interior circuits).</p>
P067	SAFETY 1	<p>Operation of the SFT input: if = 0 safety edge always enabled, if = 1 safety edge enabled only while closing, if = 2 safety edge enabled only while closing and before any movement, if = 3 safety edge enabled only when opening, if = 4 safety edge enabled only while opening and before any movement; as for the obstacle detection with internal anti-crushing sensor, also the activation of the inputs SFT1 and SFT2 causes the complete or partial reversal as set by P055 (duration of inversion on obstacles while opening, and P056 (duration of reversal on obstacle while closing)</p>
P068	SAFETY 2	

	TYPE 00	TYPE 01	TYPE 02	TYPE 03
1.....255 (motors with encoder) 1%.....100% (motors without encoder)	012	025	025	020
1.....255				
0%tot.....100%tot	000	035	000	000
0%tot.....100%tot				
<ul style="list-style-type: none"> <li>• 000: "Energy saving" not active</li> <li>• 001: "Energy saving" active</li> </ul>	000	000	000	000
<ul style="list-style-type: none"> <li>• 000: "Boost" output for electric-lock art.110 power supply</li> <li>• 001: "24V === pulse output max 5W</li> <li>• 002: "24V === step-by-step output max 5W</li> <li>• 003: "Electro-brake output for not self-locking operators</li> <li>• 004: "Output for electric-lock power supply via an external relay</li> <li>• 005: "output for electro-magnets power supply for barriers</li> <li>• &gt;005: "24V === temporized output max 5W (6sec.....255sec)</li> </ul>	000	000	000	005
<ul style="list-style-type: none"> <li>• 000: "Standard installation"</li> <li>• 001: "Inverted installation"</li> </ul>	000	000	000	000
0sec.....10sec	002	002	002	002
<ul style="list-style-type: none"> <li>• 000: "Request Maintenance disabled</li> <li>• &gt;000: "Number of operations (x 500) for required maintenance (1.....255)</li> </ul>	000	000	000	000
<ul style="list-style-type: none"> <li>• 000: "intermittent flashing light output</li> <li>• 001: "fixed flashing light output</li> </ul>	001	001	001	001
<ul style="list-style-type: none"> <li>• 000: "safety edge always enabled</li> <li>• 001: "safety edge enabled only while closing</li> <li>• 002: "safety edge enabled only while closing and before any movement</li> <li>• 003: "safety edge enabled only when opening</li> <li>• 004: "safety edge enabled only while opening and before any movement</li> </ul>	000	000	000	000
	000	000	000	000

OPERATING PARAMETERS	P069	Delay on limit switch detection: the operation is stopped after 1,5 sec from limit switch detection. When during this delay a stop is detected, the operator is suddenly stopped
	P070	Adjustment of acceleration durability <b>Warning:</b> if soft start is activated, the acceleration is deactivated independently from P070 value.
	P071	Safeties self-test: if = 0 24V == output with autotest disabled; if = 1 24V == output for safeties with self-test (it turn the output off and check the contact opening before each maneuver). <b>Attention:</b> In order to work in self-test mode, all devices must be connected to the stabilized output 24V_ST (1-2), and be wired and aligned before the motor stroke learning (P003).
	P072	Activation of SAS function ( <b>with NET_EXP only</b> ): SAS output is connected to an input STOP / SAS INPUT of a second control panel, causing the operation “trap man” (disabling the opening of the second door as long as the first is not completely closed). If this parameter is enabled after a reset, it performs an automatic RESP during which the SAS output is not activated. If limit switches are present and they are crushed after a reset, the RESP is not executed. <b>Warning:</b> if both doors are manually unlocked and moved from the closed position creates the interlock condition. You will then need to manually close at least one of the two doors.
	P073	<b>Forced “Hold to Run”:</b> if this function is enabled, all inputs configured as OPEN and CLOSE change automatically also to OPEN UP and CLOSE UP (hold-to-run commands) if activated and kept active in case a safety contact (photocell and/or safety edge) is triggered. This function thus allows to control the automation even in case the safety devices are faulty. If the input is no longer maintained active, the automation returns to automatic operation. When using safety edges configured as SAFETY 1 or SAFETY 2, this function is not compatible with the values 001 and 003 of parameters P067 and P068. <u>For security reasons, we recommend that you DO NOT use this function in case there are any clocks/timers connected to the inputs configured as OPEN or CLOSE.</u>
	P074	Unused parameter
	P075	Unused parameter
	P076	Unused parameter
	P077	Unused parameter
	P078 ... P099	<b>Configuration parameters dedicated to the expansion card NET_EXP (for a detailed description of the parameters, refer to the instruction manual).</b>

		TYPE 00	TYPE 01	TYPE 02	TYPE 03
	<ul style="list-style-type: none"> <li>• 000: "limit switch delay disabled"</li> <li>• 001: "limit switch delay enabled"</li> </ul>	000	000	000	000
	<ul style="list-style-type: none"> <li>• 000: "acceleration deactivated (it runs an acceleration of minimum durability, almost imperceptible)"</li> <li>• 00X: "adjusts the acceleration durability at 1,5 sec (X*6 ms)"</li> </ul>	200	200	200	200
	<ul style="list-style-type: none"> <li>• 000: "net power supply (safeties self-test disabled)"</li> <li>• 001: "safeties self-test enabled"</li> </ul>	000	000	000	000
	<ul style="list-style-type: none"> <li>• 000: "SAS function" deactivated</li> <li>• 001: "SAS function" activated</li> </ul>	000	000	000	000
	<ul style="list-style-type: none"> <li>• 000: function disabled</li> <li>• 001: function enabled (forces switch to Hold-to-run mode when safeties are triggered and OPEN/CLOSE commands are maintained)</li> </ul>	000	000	000	000
		/	/	/	/
		/	/	/	/
		/	/	/	/
		/	/	/	/
		/	/	/	/



## NET24N/C

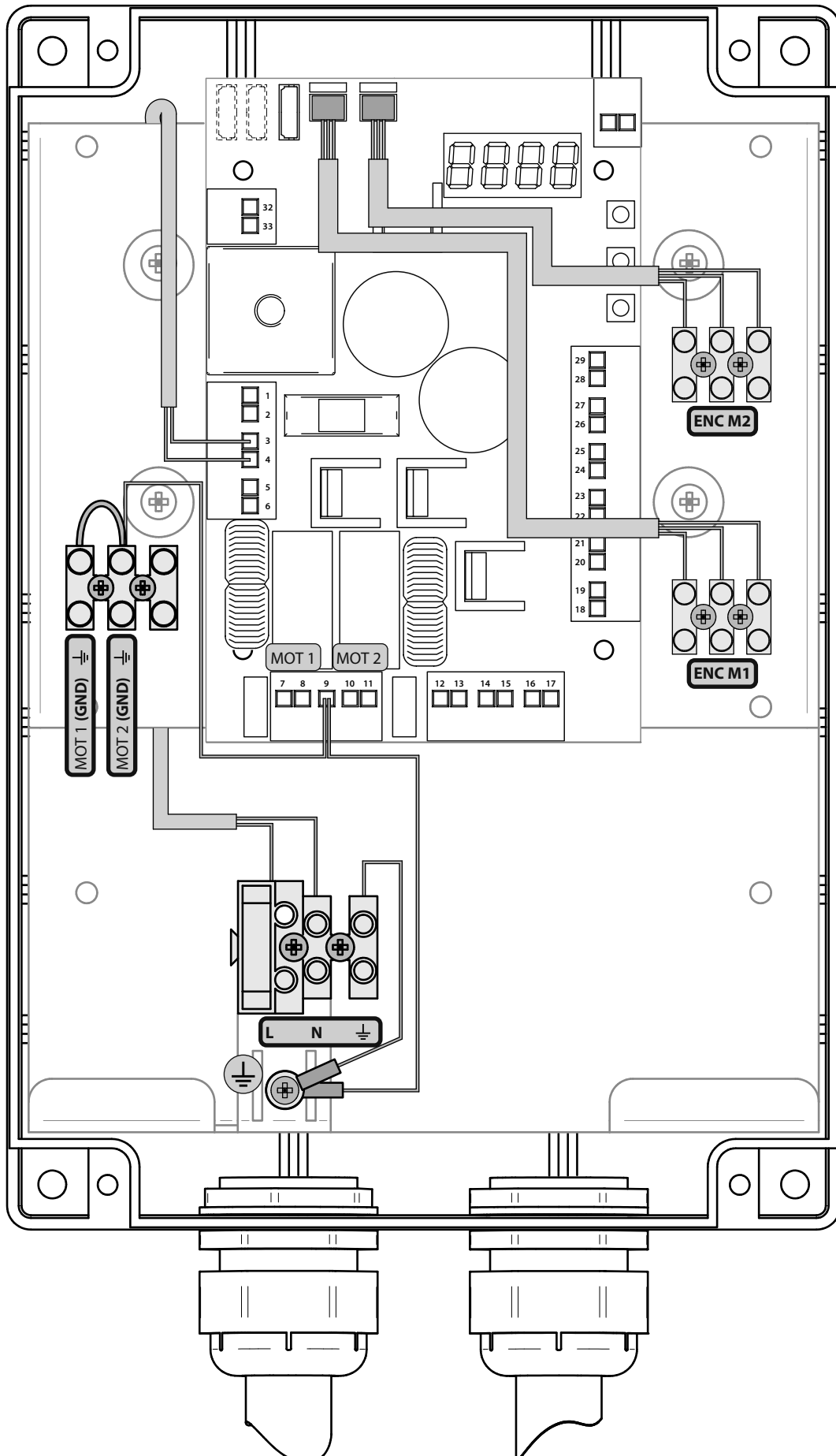



# EU Declaration of Conformity (DoC)

Company name:	DEA SYSTEM S.p.A.
Postal address:	Via Della Tecnica, 6
Postcode and City:	36013 Piovene Rocchette (VI) - ITALY
Telephone number:	+39 0445 550789
E-Mail address:	deasystem@deasystem.com

declare that the DoC is issued under our sole responsibility and belongs to the following product:

Apparatus model/Product:	NET24N - NET24N/C
Type:	Universal control panel for 24V operators
Batch:	See the label on the back of the user manual

The object of the declaration described above is in conformity with the relevant Union harmonisation legislation:

2014/53/EU (RED)  
2011/65/EU (RoHS)

The following harmonised standards and technical specifications have been applied:

Title:	Date of standard/specification
EN 63000	2018
EN 61000-6-2	2005 + AC:2005
EN 61000-6-3	2007 + A1:2011 + AC:2012
ETSI EN 301 489-1	2019 V2.2.3
ETSI EN 301 489-3	2021 V2.1.2
EN 60335-1	2012 + AC:2014 + A11:2014 + A13:2017 + A1:2019 + A2:2019 + A14:2019
ETSI EN 300 220-1	2018 V3.2.1
ETSI EN 300 220-2	2018 V3.2.1

Additional information

Signed for and on behalf of:		
Revision:	Place and date of issue:	Name, function, signature
04	Piovene Rocchette (VI) 23/09/2022	Tiziano Lievore (Administrator) 